

## Product Description

The Sirenza Microdevices' SRF-2016 is a quadrature demodulator RFIC designed for UHF and microwave receiver IF applications. This device features switchable gain control, high P1dB, and excellent I/Q amplitude and phase balance.

Use of this highly integrated device can result in lower component count, a more compact assembly, and higher transceiver card yields. The device is packaged in an industry standard 16 pin TSSOP with exposed paddle for superb RF and thermal ground.

The matte tin finish on Sirenza's lead-free package utilizes a post annealing process to mitigate tin whisker formation and is RoHS compliant per EU directive 2002/95. This package is also manufactured with green molding compounds that contain no antimony trioxide nor halogenated fire retardants.

### Functional Block Diagram

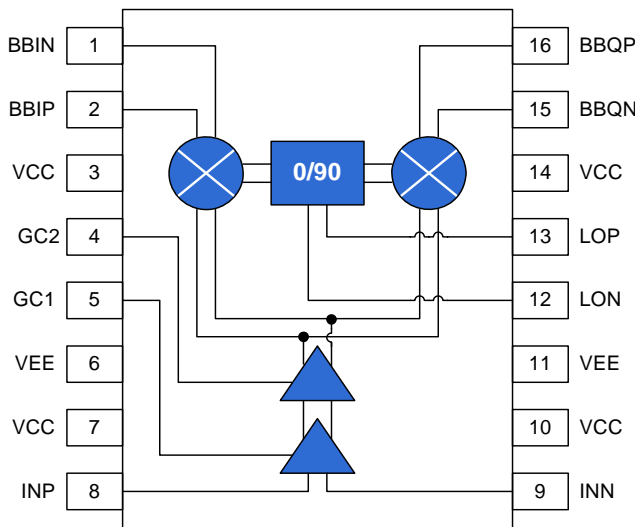

### Product Specifications – I/Q Output

Parameters	Additional Test Conditions	Unit	Min.	Typ.	Max.
I/Q Output Frequency Range		MHz	DC		500
I/Q Output Amplitude Balance		dB	-0.2		0.2
I/Q Output Phase Balance		deg	-2		2
I/Q Output Common-mode Voltage		V		2.5	
I/Q Output Return Loss	50 ohm nominal differential output	dB		20	

### Product Specifications – LO Input

Parameters	Additional Test Conditions	Unit	Min.	Typ.	Max.
LO Frequency Range		MHz	200		600
LO Input Level		dBm	-3	0	+3
LO Return Loss	50 ohm nominal differential input, Note 1	dB		20	

Performance tests and ratings for Sirenza Microdevices' products were performed internally by Sirenza and measured using specific computer systems and/or components and reflect the approximate performance of the products as measured by those tests. Any difference in circuit implementation, test software, or test equipment may affect actual performance. The information provided herein is believed to be reliable at press time and Sirenza Microdevices assumes no responsibility for the use of this information. All such use shall be entirely at the user's own risk. Prices and specifications for Sirenza Microdevices' products are subject to change without notice. Buyers should consult Sirenza Microdevices' standard terms and conditions of sale for Sirenza's limited warranty with regard to its products. No patent rights or licenses to any of the circuits described herein are implied or granted to any third party. Sirenza Microdevices does not authorize or warrant any product for use in life-support devices and/or systems. Copyright 2006 Sirenza Microdevices, Inc. All worldwide rights reserved.

## SRF-2016

## SRF-2016Z



200 - 600 MHz

Silicon Germanium IF Receiver

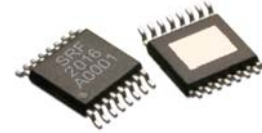

16 pin TSSOP with Exposed Ground Pad

Package Footprint: 0.197 x 0.252 inches (5.0 x 6.4 mm)

Package Height: 0.039 inches (1.0 mm)

### Product Features

- Available in Lead Free, RoHS compliant, and Green packaging
- Gain control in 20dB steps
- Excellent I/Q amplitude and phase balance
- Output P1dB > +4 dBm over all gain settings

### Applications

- Digital and spread spectrum communication systems
- Cellular, PCS, DCS, 2G, 2.5G, 3G transceivers
- ISM band transceivers
- Point-to-point microwave receivers
- Broadband wireless systems

**Product Specifications – IF Input**

Parameters	Test Conditions (see page 2)	Unit	Min.	Typ.	Max.
IF Frequency Range		MHz	200		600
INP/INN Return Loss	50 ohm nominal differential input, Note 2	dB		20	
INP/INN Common mode voltage	Internally generated	V		2	
Gain	High gain setting GC1 = GC2 = +5V	dB	28	30	32
Input P1dB		dBm	-27	-25	
Input IP2		dBm		+13	
Input IP3		dBm		-14	
DSB Noise Figure		dB		14	
Gain	Medium gain setting GC1 = +5V GC2 = 0V	dB	10	12	14
Input P1dB		dBm	-9	-7	
Input IP2		dBm		+41	
Input IP3		dBm		+3	
DSB Noise Figure		dB		17	
Gain	Low gain setting GC1 = GC2 = 0V	dB	-7	-5	-3
Input P1dB		dBm	10	12	
Input IP2		dBm		+49	
Input IP3		dBm		+24	
DSB Noise Figure		dB		33	

**Product Specifications – Miscellaneous**

Parameters	Additional Test Conditions	Unit	Min.	Typ.	Max.
Supply Voltage ( $V_{CC}$ )		V	+4.75	+5.0	+5.25
Supply Current ( $I_{CC}$ )		mA		195	
Thermal Resistance	Hot spot on die to lead	$^{\circ}\text{C}/\text{W}$		35	45
GC1, GC2 Input $V_{IL}$	Logic level zero	V	0		$0.3 \times V_{CC}$
GC1, GC2 Input $V_{IH}$	Logic level one	V	$0.7 \times V_{CC}$		$V_{CC}$
GC1, GC2 Input Impedance		kohm	40		

**Test Conditions**

$V_{CC} = +5V_{DC}$ , $T = +25^{\circ}\text{C}$ , LO Input = 0 dBm, 400 MHz, IF Input = 401 MHz			
Gain State	GC1 Voltage	GC2 Voltage	IF Power
Low Gain	0V	0V	0 dBm
Medium Gain	+5V	0V	-20 dBm
High Gain	+5V	+5V	-40 dBm

**Absolute Maximum Ratings**

Parameters	Value	Unit
Supply Voltage	6.0	$V_{DC}$
LO Input	+10	dBm
IF Input	+10	dBm
Operating Temperature	-40 to +85	$^{\circ}\text{C}$
Storage Temperature	-65 to +150	$^{\circ}\text{C}$

Operation of this device beyond any one of these limits may cause permanent damage. For reliable continuous operation the device voltage and current must not exceed the maximum operating values specified in the product specifications table.

Note 1: To achieve 20 dB port match above 100 MHz, the parasitic inductance of the package must be matched out.

Note 2: To achieve 20 dB of port match, the parasitic inductance of the package, board, and L4, L5 must be matched out at the center frequency with a series capacitor.

Package Dimensions

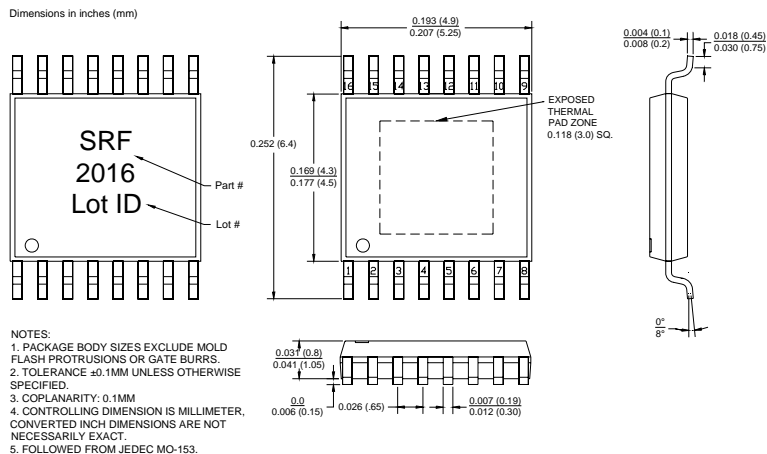

Suggested PCB Pad Layout

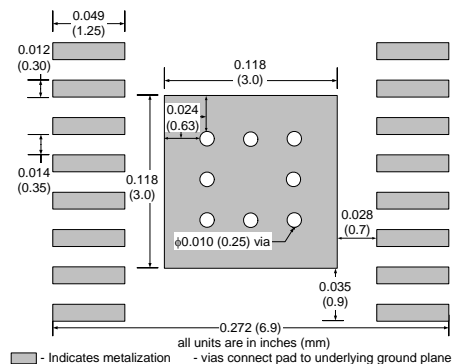

Pin Out Description

Pin #	Function	Description	Additional Comments
1	BBIN	Baseband I-axis output (-)	self-biasing
2	BBIP	Baseband I-axis output (+)	self-biasing
3	VCC	Positive power supply	
4	GC2	Gain control input, stage 2	5V CMOS levels
5	GC1	Gain control input, stage 1	5V CMOS levels
6	VEE	Ground	
7	VCC	Positive power supply	
8	INP	IF input (+)	self-biasing; AC-couple
9	INN	IF input (-)	self-biasing; AC-couple
10	VCC	Positive power supply	
11	VEE	Ground	
12	LON	LO input (-)	self-biasing; AC-couple
13	LOP	LO input (+)	self-biasing; AC-couple
14	VCC	Positive power supply	
15	BBQN	Baseband Q-axis output (-)	self-biasing
16	BBQP	Baseband Q-axis output (+)	self-biasing

Part Number Ordering Information

Number	Reel Size	Devices/Reel
SRF-2016	7"	1000
SRF-2016Z	7"	1000



Caution: ESD Sensitive

Appropriate precaution in handling, packaging and testing devices must be observed.

The Sirenza SRF-2016 is a variable gain I-Q demodulator designed for use in receiver IF sections, as shown in the figure below. It consists of five subcircuits: two cascaded switched gain stages, a matched pair of mixers, and a LO quadrature generator. This part is also available in a lower frequency version, the SRF-1016.

The gain stages are broadband differential amplifiers each with a digital control pin to set the gain. The gain control pins act independently of each other. Since the amplifiers have approximately the same gain, setting GC1 high and GC2 low results in approximately the same gain as setting GC1 low and GC2 high. The former setting is preferred because it offers better noise figure. The IF input is differential with internal bias circuitry to set the common mode voltage. The use of blocking capacitors to facilitate AC coupling is highly recommended to avoid changing the common mode voltage. Either input may be driven single-ended if the other input is connected to ground through an AC short such as a 1000 pF capacitor. This typically results in slightly lower input P1dB.

The two matched mixers are configured with the quadrature LO generator to provide in-phase and quadrature baseband outputs. These can be fed through ADCs to a DSP engine, or can be fed into a low frequency 90 degree hybrid for image rejection. Alternatively, the IF signal can be extracted from the BBI port by injecting DC into the LO port.

The LO and IF ports offer a differential 50 ohm impedance. The package (and in the case of the input port, the parallel L-R network) adds inductance that tends to degrade return loss. This can easily be matched out with a series capacitor. The 8.2 pF capacitor on the evaluation board is appropriate for 400 MHz operation; larger capacitors should be used for lower frequencies.

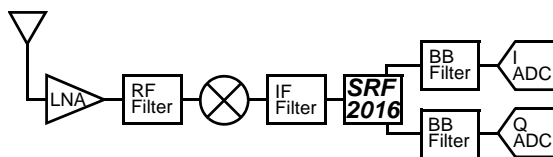

Typical use for the SRF-2016 in a receiver employing digital I/Q demodulation.

The SRF-2016 has high gain at UHF frequencies, so instability can result if there is poor power supply decoupling or undesired coupling from the input to the output. The following considerations should be observed when laying out a PC board:

- Follow the general layout of the evaluation board, keeping the power supply decoupling capacitors as close to the package as possible.
- The back of the package, the two ground pins and the decoupling capacitors should connect directly to ground, preferably to a large dedicated ground plane.
- Use the parallel L-R circuits on the input pins.
- Ensure that the input signal tracks are routed far from the output tracks.
- The Vcc pins are not internally connected, so all must be connected together externally with the specified decoupling capacitors.

The figures on page 5 illustrate a typical SRF-2016's performance with respect to temperature. Note that these numbers include the effect of the R-L network in the IF port.

The frequency response of the IF and LO ports is dominated by the L-R network on the input. When de-embedded, the gain and P1dB response is within 0.5 dB from 200 MHz to 600 MHz.

The SRF-2016 features immunity from changes in LO power. The gain typically changes by less than 0.6 dB over a 6dB range of LO power. Also note the excellent I/Q balance, which typically falls within a 0.15 dB and 1.5 degree window from 200 MHz to 600 MHz, and varies less than 0.05 dB and 0.5 degree over temperature (-40 to +85C).

The package dimensions are shown on page 3. Note that heat is removed from the part via the back side heat slug, so this slug must be properly soldered to a copper plane under the part.

Evaluation boards are available for this device, and a description of the board is shown on page 6. Note that the evaluation board uses baluns on the I/Q outputs, and these baluns limit the low frequency response of the device. For true baseband operation, the baluns should be removed, and the differential signals used directly.

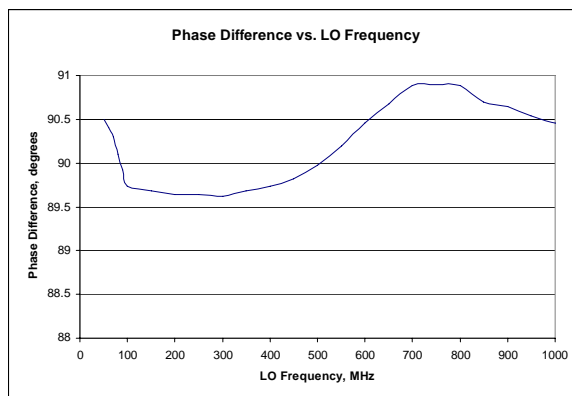
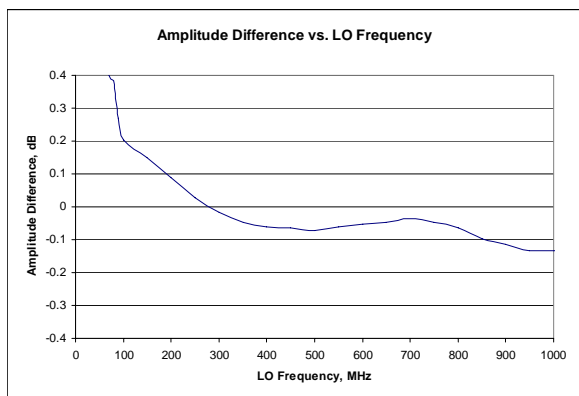
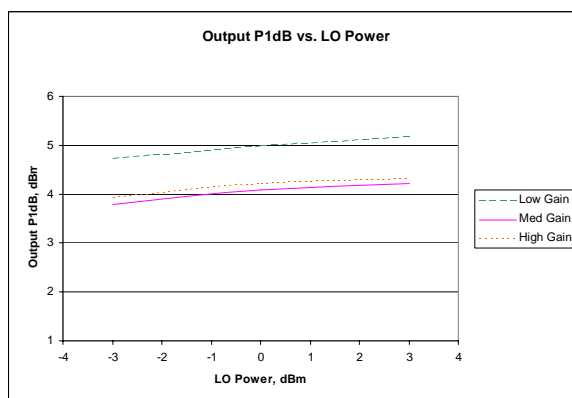
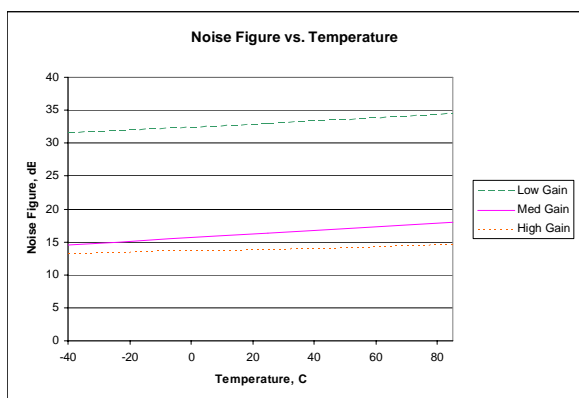
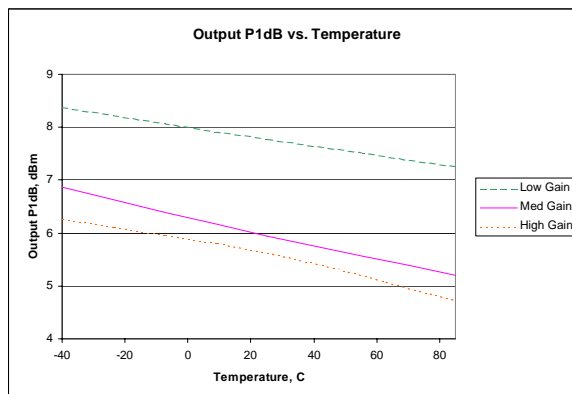
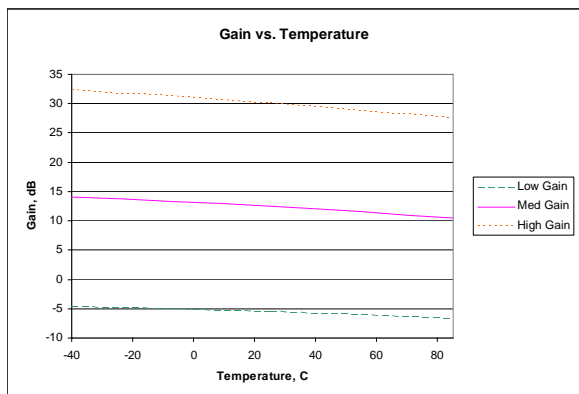

Unless otherwise stated, measurements were taken with an IF frequency of 400 MHz, an LO frequency of 401 MHz, a baseband output of 1 MHz, an LO power of 0dBm, at room temperature, with a supply voltage of 5 volts. Measurements were done on the evaluation board.

Evaluation Board Schematic

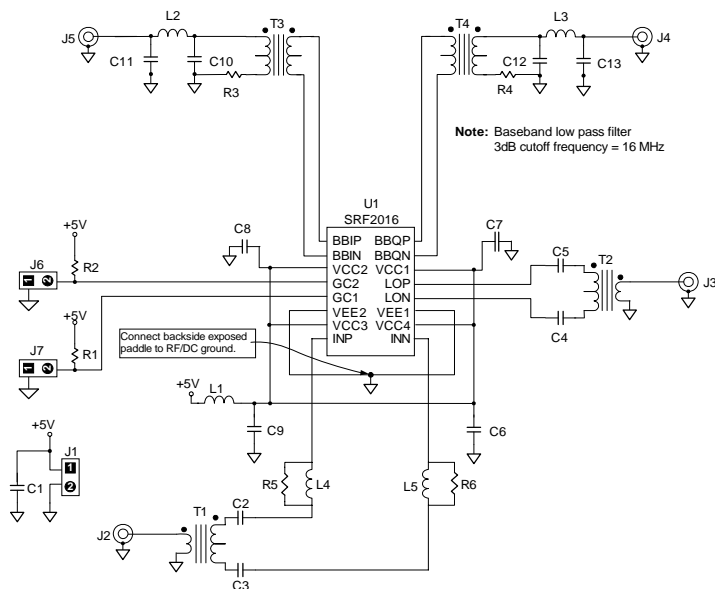

Fully Assembled PCB

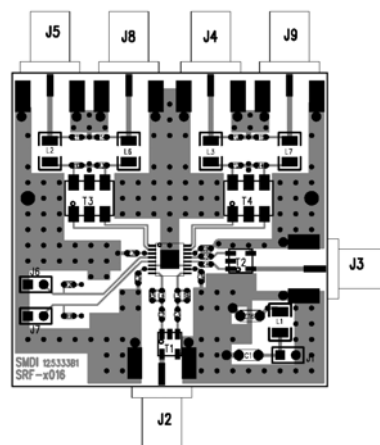

Bill of Materials (P/N SRF2016EVB, 400 MHz Evaluation Board)

Component Designator	Value	Qty	Vendor	Part Number	Description
PCB		1	SMDI	125333B1	Printed Circuit Board
U1		1	SMDI	SRF-2016	IF receiver
J1, J6, J7		3	Sullins	S1312-02-ND	2 pin 0.1" header
J2, J3, J4, J5		4	Johnson Components	142-0701-851	SMA end launch connector
T1, T2		2	Mini-Circuits	TC1-1	IF Transformer
T3, T4		2	Mini-Circuits	ADT1-6T	Baseband Transformer
C1	1 uF	1	Venkel	C1206Y5V160-105ZNE	1206 size supply bypass capacitor
C2, C3	8.2 pF	2	Venkel	C0603COG500-8R2JNE	0603 size coupling capacitor
C4, C5	15 pF	2	Venkel	C0603COG500-150JNE	0603 size coupling capacitor
C9	100 pF	1	Venkel	C0603COG500-101JNE	0603 size bypass capacitor
C6, C7, C8	22 pF	3	Venkel	C0603COG500-220JNE	0603 size bypass capacitor
C10, C11, C12, C13	220 pF	4	Venkel	C0603COG500-221JNE	0603 size filter capacitor
L1, L2, L3	1 uH	5	Panasonic	PCD1008TR-ND	1210 size filter inductor
R1, R2	1 kOhm	2	Venkel	CR0603-16W-102JT	0603 size pull-up resistor
R3, R4	0 Ohm	2	Venkel	CR0603-16W-000T	0603 jumper
R5, R6	50 Ohm	2	Venkel	CR0603-16W-500JT	0603 size stability resistor
L4, L5	10 nH	2	Toko	LL1608 FS10NJ	0603 size stability inductor

**Bill of Materials (P/N SRF-2016EVB-1, 300 MHz Evaluation Board)**

Component Designator	Value	Qty	Vendor	Part Number	Description
PCB		1	SMDI	125333B1	Printed Circuit Board
U1		1	SMDI	SRF-2016	IF receiver
J1, J6, J7		3	Sullins	S1312-02-ND	2 pin 0.1" header
J2, J3, J4, J5		4	Johnson Components	142-0701-851	SMA end launch connector
T1, T2		2	Mini-Circuits	TC1-1	IF Transformer
T3, T4		2	Mini-Circuits	ADT1-6T	Baseband Transformer
C1	1 uF	1	Venkel	C1206Y5V160-105ZNE	1206 size supply bypass capacitor
C2, C3	12 pF	2	Murata	GRM39COG120J050AD	0603 size coupling capacitor
C4, C5	18 pF	2	Murata	GRM39COG180J050AD	0603 size coupling capacitor
C9	100 pF	1	Venkel	C0603COG500-101JNE	0603 size bypass capacitor
C6, C7, C8	22 pF	3	Venkel	C0603COG500-220JNE	0603 size bypass capacitor
C10, C11, C12, C13	220 pF	4	Venkel	C0603COG500-221JNE	0603 size filter capacitor
L1, L2, L3	1 uH	5	Panasonic	PCD1008TR-ND	1210 size filter inductor
R1, R2	1 kOhm	2	Venkel	CR0603-16W-102JT	0603 size pull-up resistor
R3, R4	0 Ohm	2	Venkel	CR0603-16W-000T	0603 jumper
R5, R6	50 Ohm	2	Venkel	CR0603-16W-500JT	0603 size stability resistor
L4, L5	10 nH	2	Toko	LL1608 FS10NJ	0603 size stability inductor